

4

3

2

1

THIS DRAWING IS UNPUBLISHED. RELEASED FOR PUBLICATION JUN , 1996.
 © COPYRIGHT 1996 By - ALL RIGHTS RESERVED.

LOC	DIST	REVISIONS					
		P	LTR	DESCRIPTION	DATE	DWN	APVD
J			D3	REVISED PER ECR-15-012060	14SEP2015	I.T	W.H

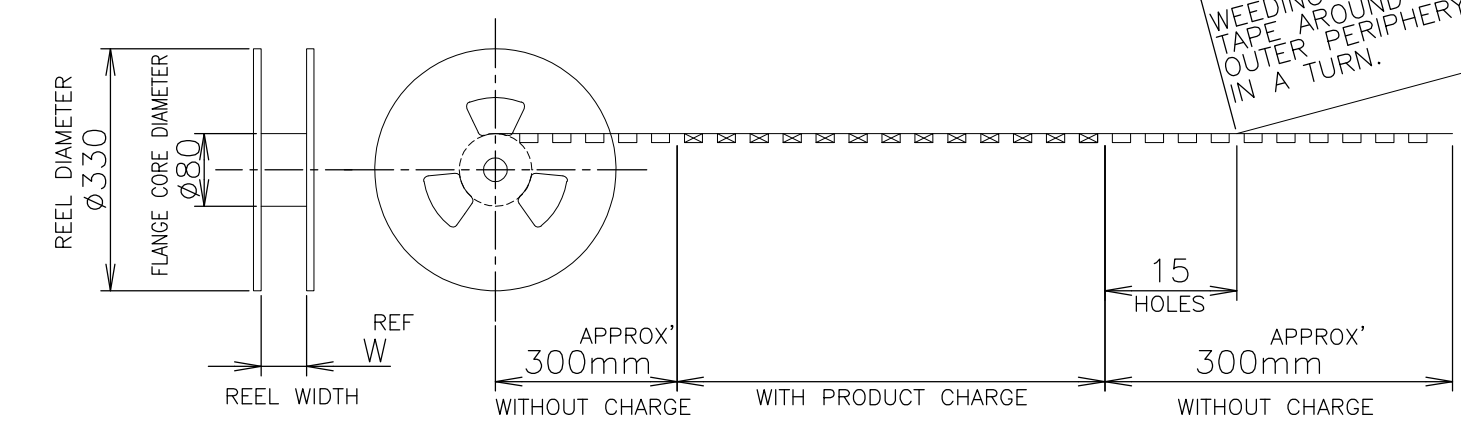
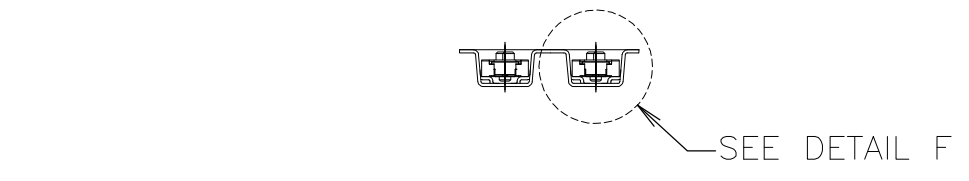
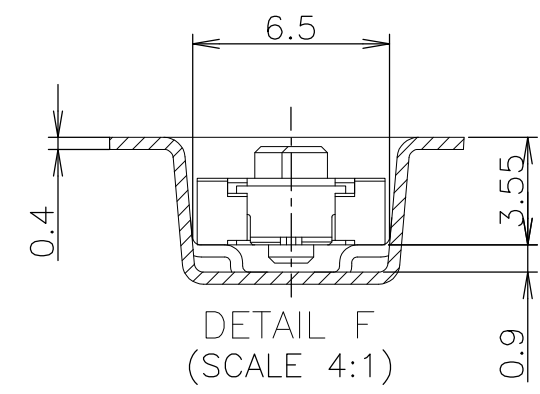
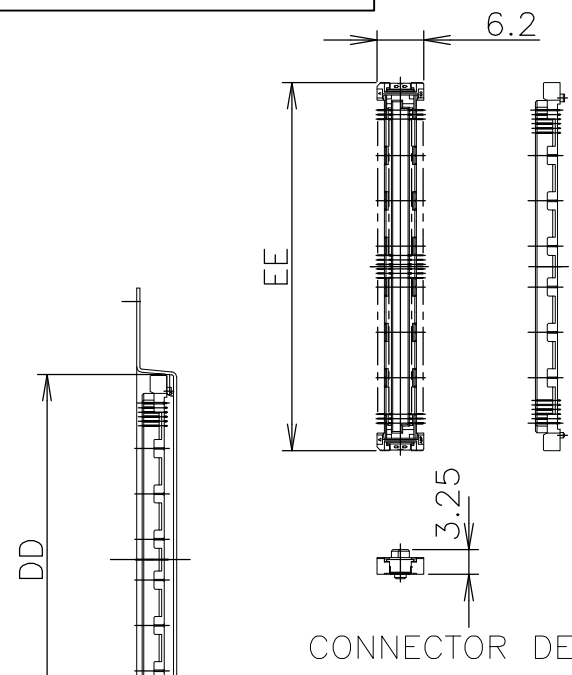
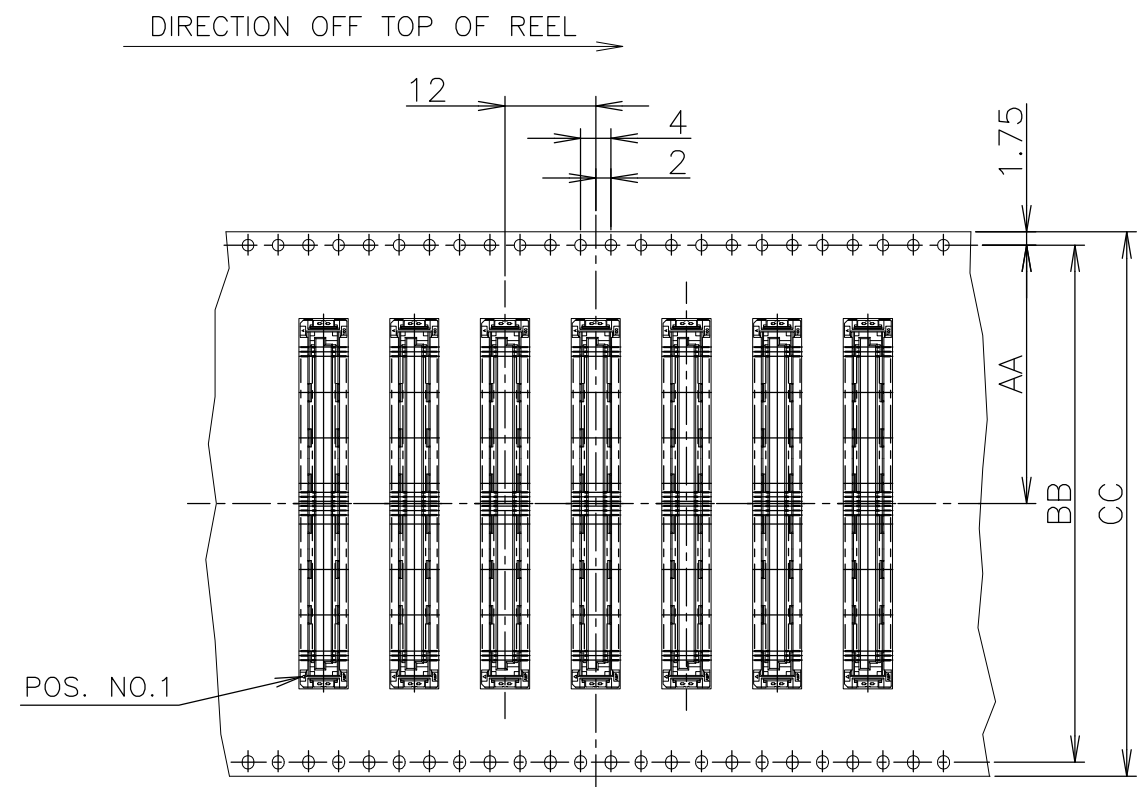

WEEDING THE COVER TAPE AROUND THE OUTER PERIPHERY IN A TURN.

SEALANT	STATUS	QTY.	FINISH	W	EE	DD	CC	BB	AA	POS.	PART NO.
NOT AVAILABLE		1000	△	77.5	54.7	55	72	68.4	34.2	160	6-5353190-1
AVAILABLE				77.5	48.7	49	72	68.4	34.2	140	6- -0
NOT AVAILABLE				61.5	42.7	43	56	52.4	26.2	120	5- -9
AVAILABLE				61.5	36.7	37	56	52.4	26.2	100	5- -8
NOT AVAILABLE				61.5	33.7	34	56	52.4	26.2	90	5- -7
NOT AVAILABLE				49.5	30.7	31	44	40.4	20.2	80	5- -6
NOT AVAILABLE				49.5	27.7	28	44	40.4	20.2	70	5- -5
NOT AVAILABLE				49.5	24.7	25	44	40.4	20.2	60	5- -4
NOT AVAILABLE				37.5	21.7	22	32	28.4	14.2	50	5- -3
NOT AVAILABLE				37.5	18.7	19	32	28.4	14.2	40	5- -2
NOT AVAILABLE	1000		△	29.5	15.7	16	24	11.5	30		5-5353190-1
AVAILABLE	1000		△	77.5	48.7	49	72	68.4	34.2	140	4-5353190-0
AVAILABLE			△	61.5	36.7	37	56	52.4	26.2	100	3- -8
NOT AVAILABLE			△	77.5	54.7	55	72	68.4	34.2	160	1- -1
AVAILABLE				77.5	48.7	49	72	68.4	34.2	140	1- -0
NOT AVAILABLE				61.5	42.7	43	56	52.4	26.2	120	-9
AVAILABLE				61.5	36.7	37	56	52.4	26.2	100	-8
NOT AVAILABLE				61.5	33.7	34	56	52.4	26.2	90	-7
NOT AVAILABLE				49.5	30.7	31	44	40.4	20.2	80	-6
				49.5	27.7	28	44	40.4	20.2	70	-5
				49.5	24.7	25	44	40.4	20.2	60	-4
NOT AVAILABLE				37.5	21.7	22	32	28.4	14.2	50	-3
				37.5	18.7	19	32	28.4	14.2	40	-2
NOT AVAILABLE	1000		△	29.5	15.7	16	24	11.5	30		5353190-1

THIS DRAWING IS A CONTROLLED DOCUMENT.

DWN LEO ZHOU 16NOV04
 CHK STEVEN YAO 16NOV04
 APVD I.ENOMOTO 16NOV04

NAME 名称
 PRODUCT SPEC 製品規格
 108-60047
 APPLICATION SPEC 取付適用規格
 114-5255

WEIGHT

STE TE Connectivity

EMBOSS ASSY
 FH 0.6BTB CONNECTOR
 REC 4H WITH G-CONTACT

SIZE A3 CAGE CODE 00779 DRAWING NO G-5353190 RESTRICTED TO

CUSTOMER DRAWING SCALE 1:1 SHEET 1 OF 3 REV D3

THIS DRAWING IS UNPUBLISHED. RELEASED FOR PUBLICATION JUN , 1996.
 © COPYRIGHT 1996 By - ALL RIGHTS RESERVED.

LOC	DIST	REVISIONS		
		P	LTR	DESCRIPTION
J		-	-	SEE SHEET 1
				DATE
				DWN
				APVD

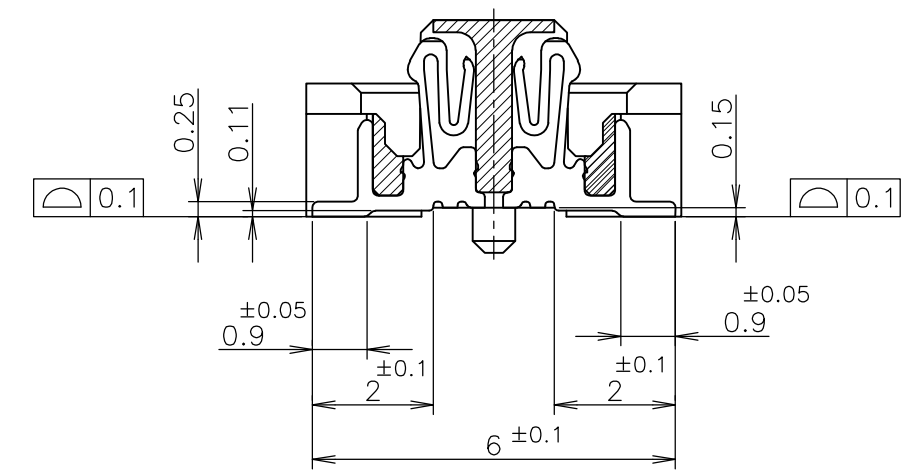
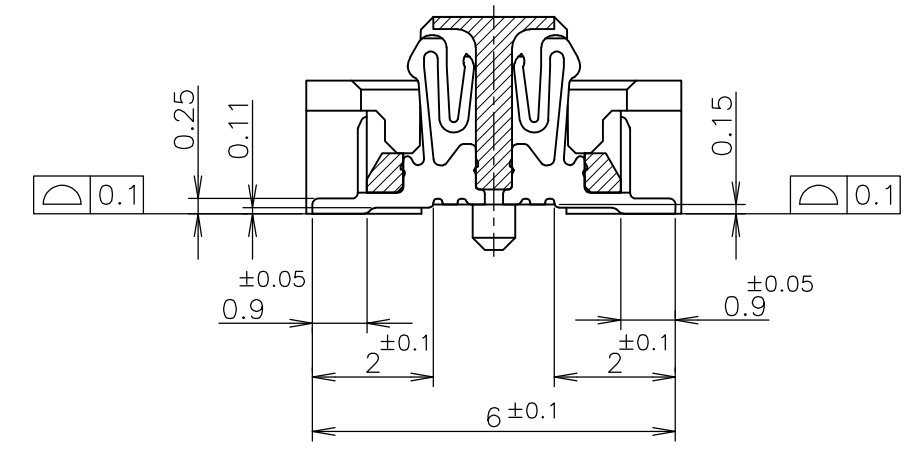
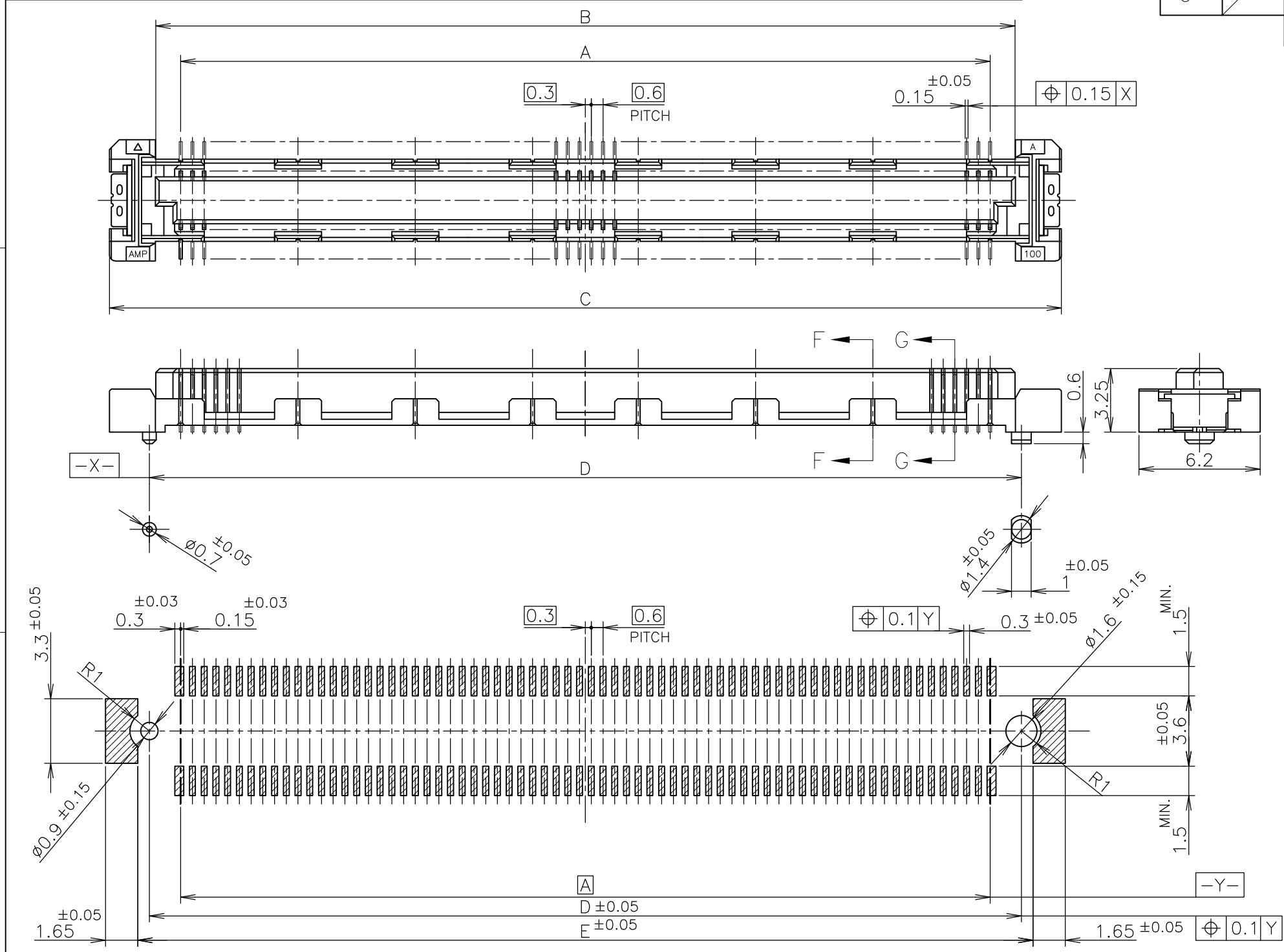

45.8	44.6	48.7	44	41.4	140	4-5353190-0		
33.8	32.6	36.7	32	29.4	100	3-8		
51.8	50.6	54.7	50	47.4	160	1-1 & 6-5353190-1		
45.8	44.6	48.7	44	41.4	140	1-0 & 6-0		
39.8	38.6	42.7	38	35.4	120	-9 & 5-9		
33.8	32.6	36.7	32	29.4	100	-8 & 5-8		
30.8	29.6	33.7	29	26.4	90	-7 & 5-7		
27.8	26.6	30.7	26	23.4	80	-6 & 5-6		
24.8	23.6	27.7	23	20.4	70	-5 & 5-5		
21.8	20.6	24.7	20	17.4	60	-4 & 5-4		
18.8	17.6	21.7	17	14.4	50	-3 & 5-3		
15.8	14.6	18.7	14	11.4	40	-2 & 5-2		
12.8	11.6	15.7	11	8.4	30	5353190-1 & 5-5353190-1		
E	D	C	B	A	POS	△ PART NO.		

REFERENCE P.C. BOARD LAYOUT

THIS DRAWING IS A CONTROLLED DOCUMENT.		DWN	STE TE Connectivity		
DIMENSIONS: 單位: 耗 mm		CHK			
TOLERANCES UNLESS OTHERWISE SPECIFIED: 一般公差		APVD	NAME 名稱		
0 PLC ± 0.3		PRODUCT SPEC 製品規格	EMBOSS ASSY		
1 PLC ± 0.3		APPLICATION SPEC 取付適用規格	FH 0.6BTB CONNECTOR		
2 PLC ± 0.3		WEIGHT	SIZE	CAGE CODE	DRAWING NO 番号
3 PLC ± 0.3		CUSTOMER DRAWING	A3	00779	G-5353190
4 PLC ANGLES ± 3'			SCALE 尺度	4:1	SHEET 2 OF 3
FINISH 仕上		RESTRICTED TO			

THIS DRAWING IS UNPUBLISHED. RELEASED FOR PUBLICATION JUN , 1996.
 © COPYRIGHT 1996 By - ALL RIGHTS RESERVED.

LOC	DIST	REVISIONS 変更			DATE	DWN	APVD
J		P	LTR	DESCRIPTION			
			-	SEE SHEET 1	-	-	-

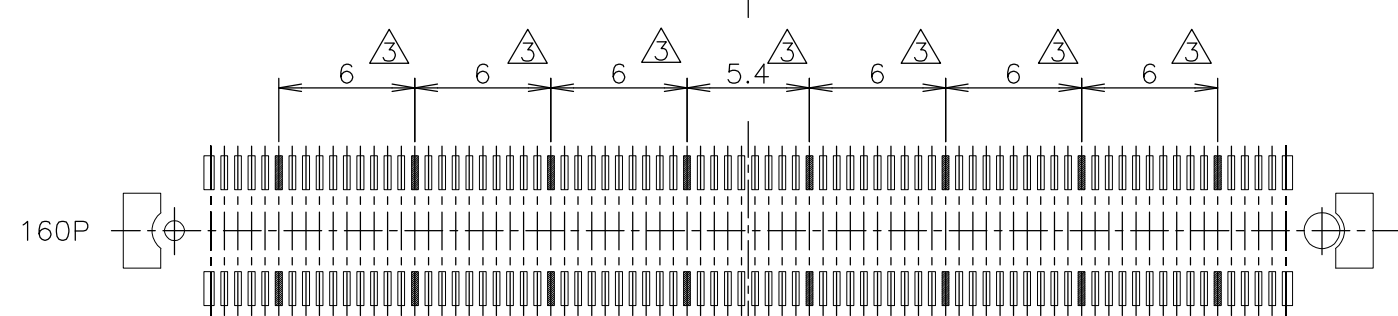
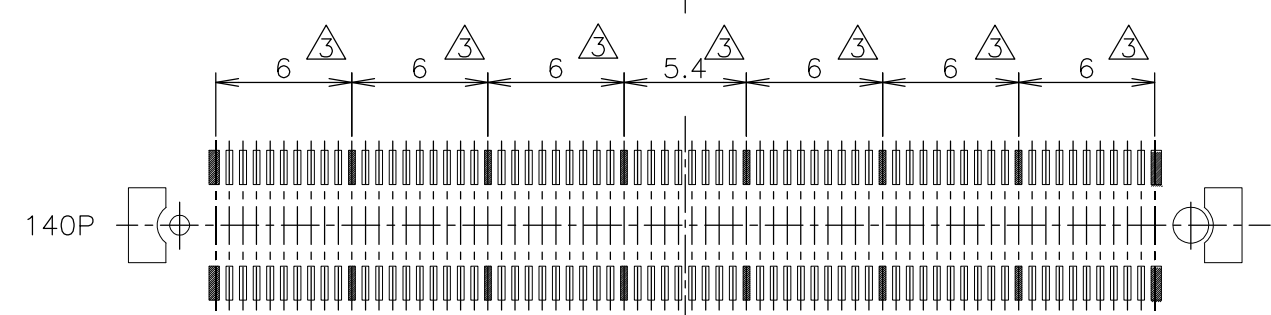
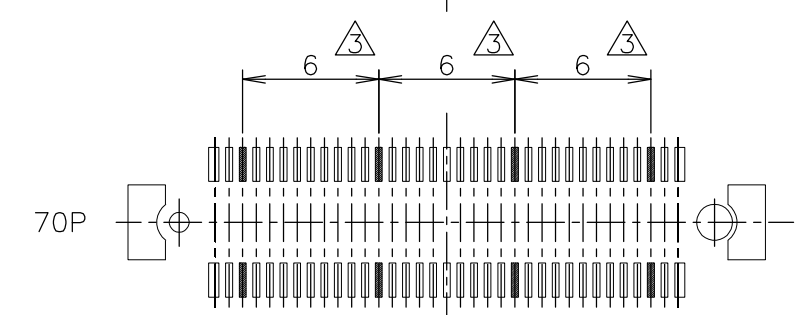
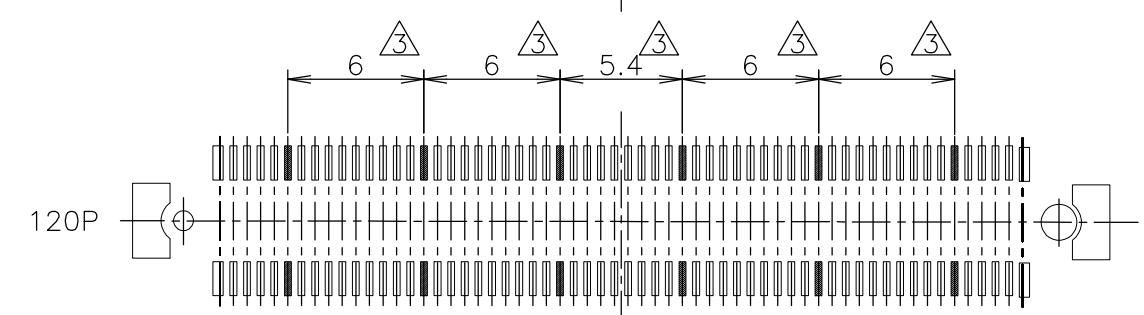
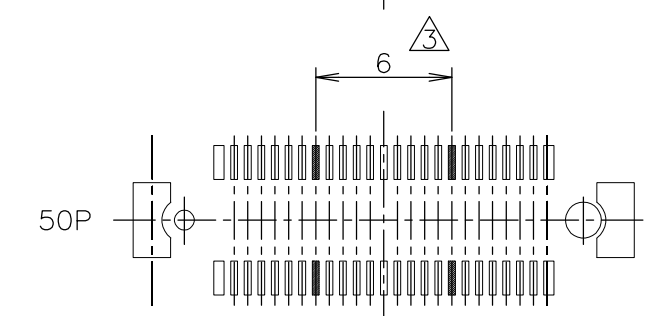
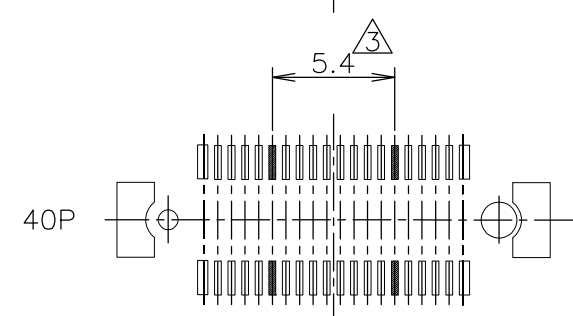
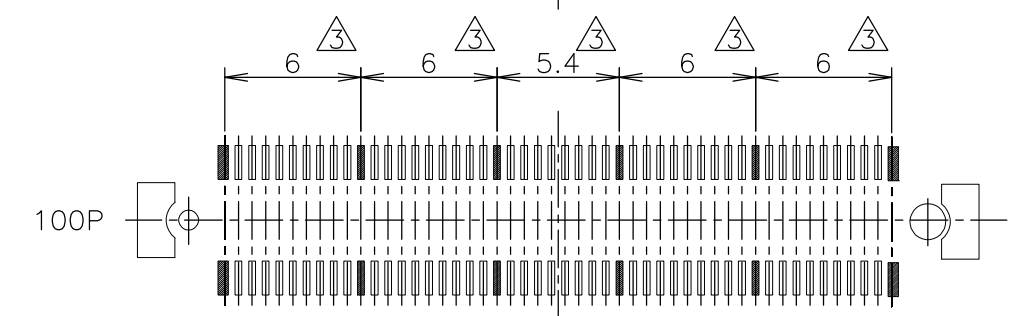
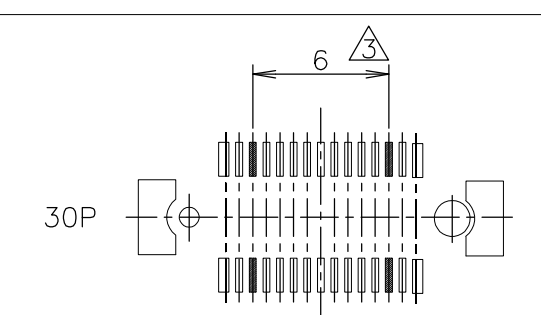
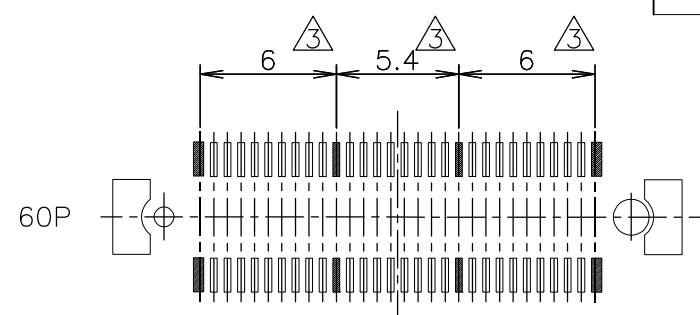
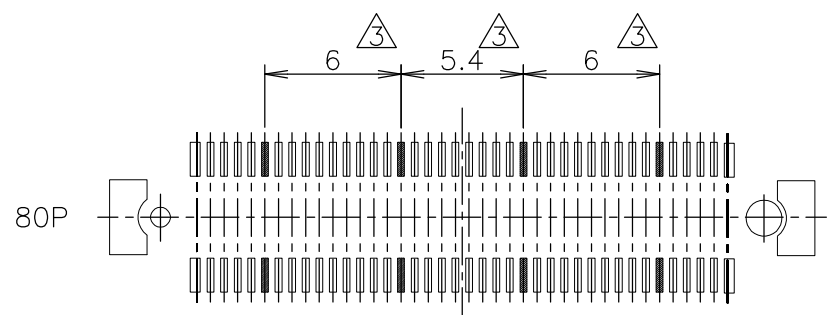

- ① MATERIAL : HOUSING : HIGH TEMP THERMO PLASTIC, UL94V-0
CONTACT : COPPER ALLOY
- ② FINISH : UNDER PL Ni 0.0013mm MIN ALL OVER.
CONTACT AREA 0.0002mm MIN Au PL.
SOLDERING AREA: SIGNAL POS 0.00005mm MIN Au PL.
GROUND POS 0.001mm MIN TIN PL.
- ③ THIS POSITION IS GROUND CIRCUIT.
- ④ PACKING ASSY DWG SEE SHEET 1.
- ⑤ THIS PRODUCT WAS COATED BY FLUX-PENETRATION
-INHIDTING AGENT.
- ⑥ FINISH : UNDER PL Ni 0.0013mm MIN ALL OVER.
CONTACT AREA 0.00076mm MIN Au PL.
SOLDERING AREA: SIGNAL POS 0.00005mm MIN Au PL.
GROUND POS 0.001mm MIN TIN PL.

THIS DRAWING IS A CONTROLLED DOCUMENT.		DWN	STE TE Connectivity		
DIMENSIONS: 単位: 耗 mm		CHK			
TOLERANCES UNLESS OTHERWISE SPECIFIED: 一般公差		APVD	NAME 名称		
0 PLC ± 0.3		PRODUCT SPEC 製品規格	EMBOSS ASSY		
1 PLC ± 0.3		APPLICATION SPEC 取付適用規格	FH 0.6BTB CONNECTOR		
2 PLC ± 0.3		WEIGHT	SIZE	CAGE CODE	DRAWING NO
3 PLC ± 0.3		CUSTOMER DRAWING	A3	00779	C-5353190
4 PLC ± 0.3			SCALE	3:1	SHEET
ANGLES ± 3'				REV	D3
FINISH 仕上					
MATERIAL 材料					